

REVISION RECORD				
REV.	DESCRIPTION	ECN No.	APPROVED	DATE

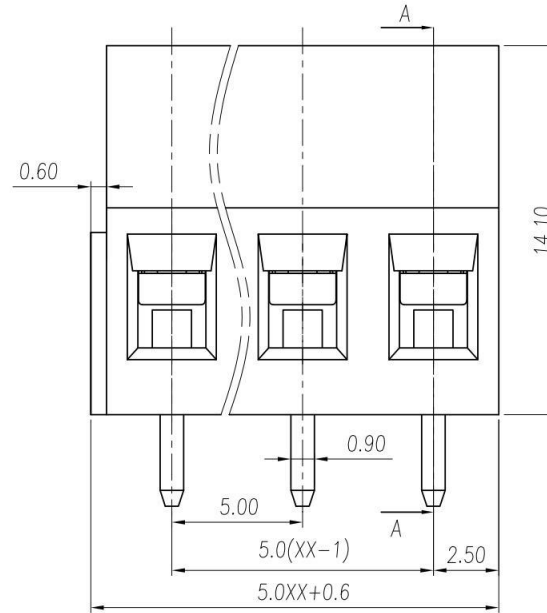
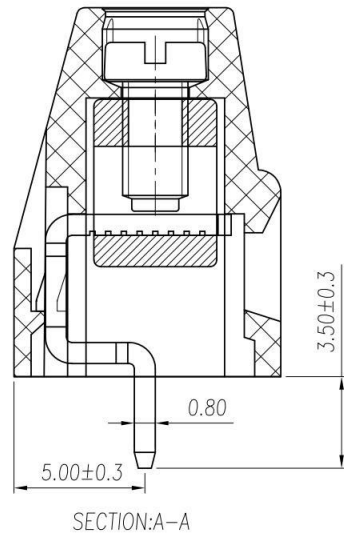
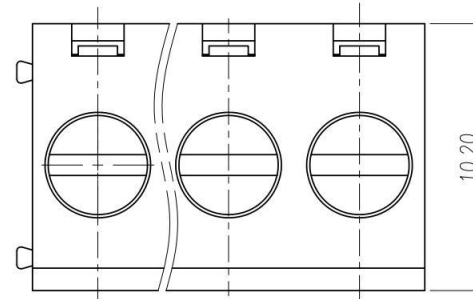
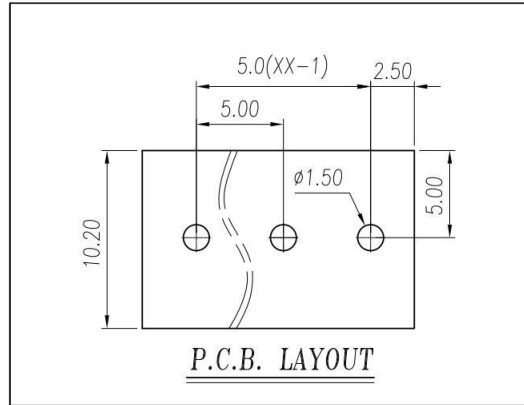

UL/CUL 技术参数				
UL/CUL Technical Data				
等级	Use Group	B	C	D
额定电压	Rated Voltage [V]	300	-	300
额定电流	Rated Current [A]	16	-	10
接线范围	Wire Range	24-12		
单/多芯线	Solid/Stranded [AWG]	24-12		
耐电压	Withstanding Voltage	1600V/1Min		
IEC 技术参数				
IEC Technical Data				
过电压类别	Overtoltage Category	III	III	II
污染等级	Contamination Class	3	2	2
额定电压	Rated Voltage [V]	250	400	630
额定电流	Rated Current [A]	24	24	24
额定冲击电压	Impulse withstand voltage ^a [KV]	4.0	4.0	4.0
导线截面积	Conductor cross section	0.5-2.5		
硬质/柔性导线	Solid/flexible [mm ²]	0.5-2.5		
材料				
绝缘材料	Insulation Material	PA66		
阻燃等级	Imflammability	UL94V-0		
导体材料	Contactior Material	铜合金 Copper alloy		
导体表面镀层	Contactive Coating	镀锡 Sn Plated		
一般参数				
间距	Pitch /极数 Poles [mm] / [P]	5.0 / 02~24		
剥线长度	Stripping Length [mm]	6~7		
螺丝	Screw/扭矩 Torque(Max) [N.m]	M2.5/0.4		
工作温度	Operating temperatur [°C]	-40~105		
引针尺寸	Pin Dimensions [mm]	0.8*0.9		
PCB板孔径	PCB Hole Diameter [mm]	Ø1.5		

linear dimension(Tolerances Standard GB/T 14486-2008)										
variable range	to 6	over 6 to 10	over 10 to 30	over 30 to 60	over 60 to 100	over 100 to 160	over 160 to 10	over 10 to 100	over 100 to 100	
tolerance	±0.20	±0.30	±0.50	±0.70	±1.00	±1.30	±1.60	0.10	0.30	0.60

Contact:sales@nbkafeng.com

单位 / UNITS	mm	尺寸 / SIZE	A4	比例 / SCALE	3.5:1	第三视角 / THIRD ANGLE PROJECTION	版本 / REV	V0
							名称 / TITLE	KF128-5.0-XXP
宁波咖峰电子有限公司 NINGBO KAFENG ELECTRONIC CO., LTD								