

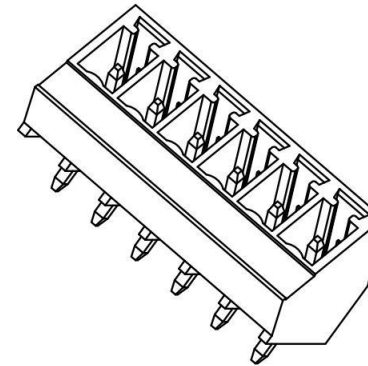

REVISION RECORD				
REV.	DESCRIPTION	ECN No.	APPROVED	DATE

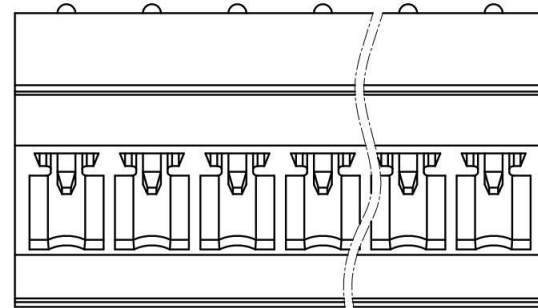

UL/CUL 技术参数 UL/CUL Technical Data				
等级	Use Group	B	C	D
额定电压	Rated Voltage [V]	300	-	300
额定电流	Rated Current [A]	8	-	8
接线范围	Wire Range	-		
单/多芯线	Solid/Stranded [AWG]	-		
耐电压	Withstanding Voltage	1600V/1Min		
IEC 技术参数 IEC Technical Data		IEC61984		
过电压类别	Overvoltage Category	III	III	II
污染等级	Contamination Class	3	2	2
额定电压	Rated Voltage [V]	160	160	320
额定电流	Rated Current [A]	7	7	7
额定冲击电压	Impulse withstand voltagea [KV]	2.5	2.5	2.5
导线截面积	Conductor cross section	-		
硬质/柔性导线	Solid/flexible [mm <sup>2</sup> ]	-		
材料		Material		
绝缘材料	Insulation Material	PA66		
阻燃等级	Imflammability	UL94V-0		
导体材料	Contact Material	铜合金 Copper alloy		
导体表面镀层	Contactive Coating	镀锡 Sn Plated		
一般参数		Other Data		
间距	Pitch / 极数 Poles [mm] / [P]	3.81 / 02~24		
剥线长度	Stripping Length [mm]	-		
螺丝	Screw/ 扭矩 Torque(Max) [N.m]	-		
工作温度	Operating temperatur [°C]	-40~105		
引针尺寸	Pin Dimensions [mm]	0.8*0.8		
PCB板孔径	PCB Hole Diameter [mm]	Ø1.2		

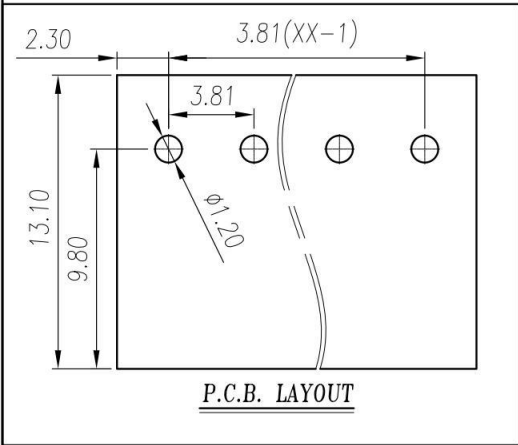

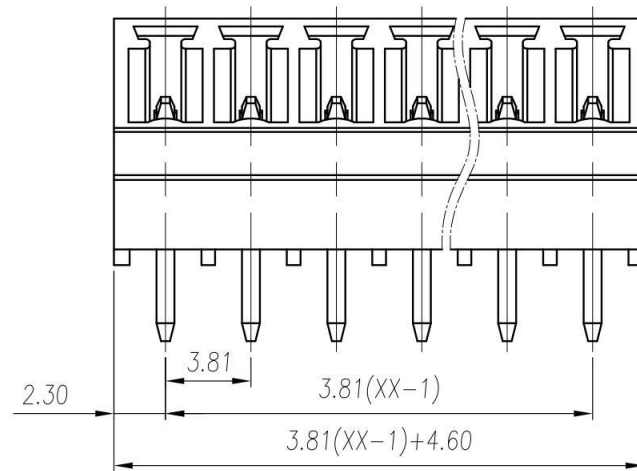
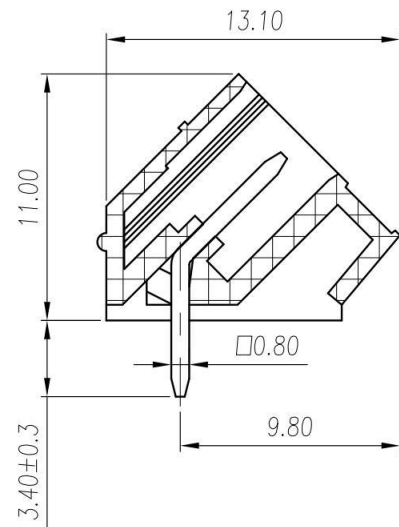
linear dimension(Tolerances Standard GB/T 14486-2008)										
variable range	to 6	over 6 to 10	over 10 to 30	over 30 to 60	over 60 to 100	over 100 to 160	over 160 to 250	over 250 to 500	over 500 to 1000	
tolerance	±0.20	±0.30	±0.50	±0.70	±1.00	±1.30	±1.60	0.10	0.30	0.60

Contact:sales@nbkafeng.com

单位/UNITS	mm	尺寸/SIZE	A4	比例/SCALE	3:1	第三视角/THIRD ANGLE PROJECTION	版本/REV	V0
宁波咖峰电子有限公司 NINGBO KAFENG ELECTRONIC CO.,LTD							名称/TITLE	KF15EDGLC-3.81-XXP