

REVISION RECORD				
REV.	DESCRIPTION	ECN No.	APPROVED	DATE

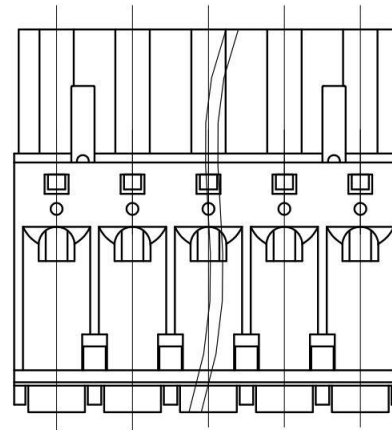
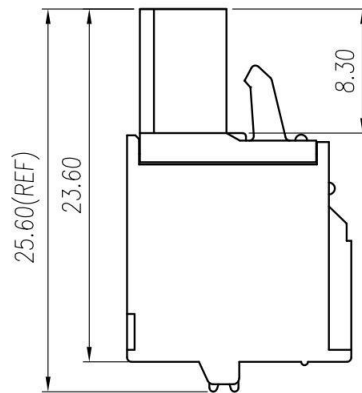
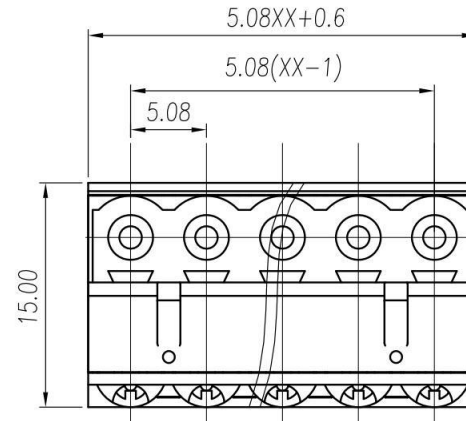

UL/CUL 技术参数 UL/CUL Technical Data		UL® us		
等级	Use Group	B	C	D
额定电压	Rated Voltage [V]	300	-	300
额定电流	Rated Current [A]	10	-	10
接线范围 单/多芯线	Wire Range Solid/Stranded [AWG]	28-12		
耐压	Withstanding Voltage	1600V/1Min		
IEC 技术参数 IEC Technical Data		IEC61984		
过电压类别	Overvoltage Category	III	III	II
污染等级	Contamination Class	3	2	2
额定电压	Rated Voltage [V]	250	320	630
额定电流	Rated Current [A]	12	12	12
额定冲击电压 Impulse withstand voltage	[KV]	4.0	4.0	4.0
导线截面积 硬质/柔性导线	Conductor cross section Solid/flexible [mm²]	0.2-2.5		
材料 Material				
绝缘材料	Insulation Material	PA66		
阻燃等级	Imflammability	UL94V-0		
导体材料	Contacting Material	铜合金 Copper alloy		
导体表面镀层	Contactive Coating	镀锡 Sn Plated		
一般参数 Other Data				
间距	Pitch / 极数 Poles [mm] / [P]	5.08 / 02~24		
剥线长度	Stripping Length [mm]	7~8		
螺丝	Screw/ 扭矩 Torque(Max) [N.m]	-		
工作温度	Operating temperature [°C]	-40~105		
焊锡温度	Soldering temperature	-		
引针尺寸	Pin Dimensions [mm]	-		
PCB板孔径	PCB Hole Diameter [mm]	-		

linear dimension(Tolerances Standard GB/T 14486-2008)							—	∠	⊥	
variable range	to 6	over 6 to 10	over 10 to 30	over 30 to 60	over 60 to 100	over 100 to 160	to 10	over 10 to 100	over 100 to	
tolerance	±0.20	±0.30	±0.50	±0.70	±1.00	±1.30	±1.60	0.10	0.30	0.60

Contact:sales@nbkafeng.com

单位 / UNITS	mm	尺寸 / SIZE	A4	比例 / SCALE	2:1	第三视角 / THIRD ANGLE PROJECTION	版本 / REV	V0
宁波咖峰电子有限公司 NINGBO KAFENG ELECTRONIC CO., LTD						名称 / TITLE	KF2EDGKD-5.08-XXP	